

AVHSA 2010 Officers and Delegates

President

Ronnie Beasley
143 Maewen Circle
Russellville, AR 72802
Mobile#: 479-970-0175
Home#: 479-880-2433
Work#: 479-880-8077

E-mail#: rmbeasley@suddenlink.net

Treasurer

Jolene Maupin
13535 N State Hwy 28
Dardanelle, AR 72834
Home#: 479-576-2872
Mobile#: 479-264-1722
E-Mail: jbmaupin@centurytel.net

Vice President

Dale Burgess
17151 E. State Hwy 155
Dardanelle, AR 72834
Home#: 479-229-2582
Mobile#: 479-970-5891

Show Secretary

Carole Bittle
20601 N. State Hwy 7
Dardanelle, AR 72834
Mobile#: 501-339-6584
E-Mail: carole.bittle@suddenlink.com

Recording Secretary

Cheryl A. Padgett
32 Heath Lane
Greenbrier, AR 72058
Home#: 501-679-4126
Mobile#: 501-690-1398
FAX#: 501-375-7230
E-mail: cheryl@cei.net

Delegates

Atkins

Jennifer Williams
3205 SR 326
Russellville, AR 72802
Home#: 479-890-2524
Work#: 479-857-4544
E-mail: jmwill175@yahoo.com

Farrah Beldin
3930 SR 326
Russellville, AR 72802
Home#: 479-641-1237
Work#: 479-890-4003
E-mail: beldin812@hotmail.com

Caroline Jennen
12030 N State Hwy 28
Dardanelle, AR 72834
Home#: 479-576-2260
Mobile#: 501-516-0155
E-mail: cty84061@centurytel.net

Pope

Brock Vest
10 Oak Hill Lane
Greenbrier, AR 72058
Mobile#: 501-341-9142
Work#: 501-683-2222
E-mail: vest511@yahoo.com

Faulkner

DeLanna Lacy
14 N. Lake Circle
Conway, AR 72032
Home#: 501-329-5856
Mobile#: 501-336-7381
E-mail: dlacy@alliancecable.net

Donna Dayer
3270 Nutter Chapel Rd
Conway, AR 72034
Home#: 501-336-4292
Mobile#: 501-733-1789
E-mail: donnadayer@conwaycorp.net

Chris Merritt
10310 Nebo Acres
Dardanelle, AR 72834
Home#: 479-229-5817
Mobile#: 501-339-6584
E-mail: rmerrit1@centurytel.net

Yell

Dale Burgess
17151 E. State Hwy 155
Dardanelle, AR 72846
Home#: 479-229-2582

Perry

Larry Brazil
1580 Hwy 216
Houston, AR 72070
Home#: 501-889-2115
Mobile#: 501-889-4134
E-mail: trigger2115@windstream.net

Debbie Zinser
1910 Hwy 300
Bigelow, AR 72016
Mobile#: 501-977-6212
E-mail: Zinser@arbbs.net

CONTENTS

By-laws, Rules, and Regulations.....	3
Name.....	3
Purpose.....	3
Membership.....	3
Fees.....	3
Meetings.....	3
Board of Directors.....	4
Officers.....	4
Approved Shows.....	4
General Show Rules.....	5
Age Divisions.....	7
Show Results.....	7
High Point Awards.....	7
Junior and Senior Divisions.....	8
Show Manager.....	8
Judges.....	8
Ringmaster.....	8
Announcer.....	9
Other Show Personnel.....	9
Facilities.....	9
Amendment of By-Laws.....	9
State Horse Show Association.....	9
Approved Events.....	10
Lead In Class.....	10
Beginner Walk Trot Class.....	10
Beginner Barrels and Poles.....	10
Walk Trot Class.....	10
Open Walk Trot Class.....	10
Queens Class.....	10
Pony Under Saddle.....	11
Two-Year Old Snaffle Bit Class.....	11
Buckaroo Horsemanship.....	11
Youth Horsemanship.....	11
Western Pleasure.....	11
Ranch Horse Western Pleasure.....	12
Junior Horse Pleasure.....	12
Gaited Pleasure.....	12
Slow Gaited Pleasure.....	12
Open Hunter Under Saddle.....	13
Barrel Race.....	14
Pole Bending Class.....	15
Flag Race.....	16
Speed Race.....	17
Keyhole Race.....	17
Barrel Pick-up.....	18
Reining.....	19

ARKANSAS VALLEY HORSE SHOW ASSOCIATION

By-Laws, Rules, and Regulations

NAME

This association shall be known as the Arkansas Valley Horse Show Association and shall at all times be operated and conducted as a non-profit organization in accordance with the laws of the State of Arkansas providing for such organizations, and by which all such rights granted to Associations of this kind.

PURPOSE

The purpose of this Association shall be to coordinate and encourage better horse shows; to prevent conflicting show dates; to set up and help regulate a standard of rules and regulations to be followed by all Association approved shows in this district; and to encourage good sportsmanship.

MEMBERSHIP

Membership in this Association is extended to horse clubs in the Central Arkansas area interested in the promotion of horse shows and willing to meet the requirements of this Association. Membership is contingent upon Board approval.

The Board of Directors shall have the power to drop from the roll, any club, which has failed to comply with the rules, by-laws, and regulations of this Association, or a club, which the Board thinks, has not given sufficient support to this Association's approved shows.

Club membership in this Association automatically includes all members in good standing of the said clubs.

FEES

Membership dues are \$25.00 per year for each club. Dues must be paid each year before the first of March. An additional fee of 50 % of the gross entry fees from each show shall be paid to the Association no later than one week following an approved show. Additional assessments may be voted on as deemed necessary by the Board of Directors. State turn back money will go into the AVHSA treasury General Fund.

MEETINGS

The fiscal year of this Association shall be October 1 to September 30. The show season shall begin no earlier than April 1 and end no later than one week prior to the state show. The President of the Association will announce the time and place for the first meeting of the year and the Board of Directors will decide upon the dates and places of subsequent meetings. Special meetings may be called by the President or by a majority vote of the Board. In order for all members to be present at a called meeting at a horse show, if the Board needs to take a vote on something other than an emergency for the show, it is to be announced at the beginning of the show.

BOARD OF DIRECTORS

The Board of Directors shall consist of two (2) representatives (voting delegates) from each club in good standing. Each representative must be at least 21 years of age, on January 1st. They shall be appointed by their clubs and shall serve until his or her successor is appointed. A club will have the right to send a substitute representative in the event their regular representative cannot attend a given meeting. The President of the Board will not be counted as a voting delegate.

The business and property of the Association shall be managed and controlled by the Board of Directors and its duly elected officers. A majority of the number of Directors shall constitute a quorum for the transaction of the business.

OFFICERS

Officers shall be elected at the final meeting of each fiscal year by a majority vote of the duly appointed representatives of each club in good standing. The Elected officers of the Association shall be the President, the Vice President, the Treasurer, and the Show Secretary. The President will appoint the Association Secretary.

PRESIDENT: The President shall be the chief executive officer of the Association and shall preside at all meetings of the Board of Directors. He or she shall see that the By-Laws, Rules, and Regulations of the Association are enforced and shall perform all other duties that may be prescribed from time to time by the Board. He or she shall vote only in the case of a tie.

VICE PRESIDENT: The Vice President, in the absence of the President, shall have the power and shall perform duties of the President, and have such other duties as may be prescribed by the Board of Directors.

ASSOCIATION SECRETARY: The Secretary shall keep the permanent records of the Association and the minutes of all its meetings, which shall be read, at the beginning of each meeting. He or she shall keep accurate membership records, including addresses and telephone numbers of each club's delegates, and shall handle all the administrative correspondence for the Association, including notices of meetings, rule changes, etc., whenever necessary.

TREASURER: The Treasurer shall receive all income for this Association and shall deposit it to the credit of the Arkansas Valley Horse Show Association in the bank of his or her choice. Disbursements shall be made by check upon itemized demands or by order of the Board, and an accurate record of all receipts and disbursements shall be kept in a manner permitting a clear report to be made at each meeting.

SHOW SECRETARY: The Show Secretary shall collect and keep all records of Association shows results including complete entry lists. Mail results to Show Secretary no later than Tuesday after each show.

The Show Secretary will be responsible for furnishing all member clubs with the results after each approved show.

APPROVED SHOW

Clubs desiring to put on a horse show, which will be recognized by the Arkansas Valley Horse Show Association and which will include the awarding of points to the top five riders in each class must obtain the approval of the Board of Directors and meet the following requirements:

1. Be a member of the Association in good standing with all dues paid;
2. Have a show date approved by the Board of Directors. Once the Association show dates are set at the beginning of the year, a date change must be brought up at one meeting and voted on at the following meeting. A majority vote is needed to change a date;
3. Agree to abide by all rules and regulations set forth by this Association;

4. Must have the mandatory classes, which this Association has adopted before any other events, which this club might want to add. No closed classes allowed at an approved show.
5. Events shall be scheduled in the order prescribed by the Association which will provide an equitable rotation of all classes, except Lead In, Beginner Walk Trot, Walk Trot, Queen's, and Pony Under Saddle, which will be scheduled first at each show;
6. AVHSA will have a minimum of six shows. No more than one member club will be allowed to have only one show a year. If contested by another member club of the Association (AVHSA) the club with the most recent single show season will pick up two shows and allow the contesting club to have one show.

GENERAL SHOW RULES

1. A rider may ride only one horse in each class. Each horse may have only one rider.
2. Riders in the Buckaroo and Junior age groups will not be allowed to show a stallion in any judged events, including Queen's Class and Pony Class; the only exception will be Junior Reining and speed events.
3. All riders must wear hats in judged events, except in gaited pleasure where hats for ladies are optional.
4. Numbers must be placed on both sides of the horse, attached to the saddle pad for all Western Pleasure events, Horsemanship and Reining. Hunter Under Saddle, Ladies and Men's Gaited may be worn on both sides of the pad or on the back of the rider.
5. No show is complete until all ties to fifth place have been worked off.
6. No exhibition rides will be made during a show, but may be made after the show if arrangements are worked out with the sponsoring club.
7. Entry fees will not be refunded to a person pulling out of a class unless there is sickness or injury to rider or horse.
8. A rider in any event must ride with a saddle.
9. Individual High Point. High Point awards will be given to the high point Pee Wee, Buckaroo, Junior, and Senior rider Classes according to the Board's discretion.
 - a) Pee Wee High Point will be earned from Walk Trot, Pony Under Saddle, Pony Barrel, and Pony Poles.
 - b) All ties will be broken according to the number of 1sts, 2nds, 3rds, etc. that each rider has.
 - c) Queen's, Lead In, and all beginner classes do not count toward high point.
10. Riders wearing crop tops, muscle shirts, or any sleeveless garments will not be allowed to show. Tops must have sleeves and shirttails long enough to be tucked in. No cap or rolled up sleeves.
11. All contestants will wear boots, except for speed events where A heels down type riding shoes will be allowed.
12. In case of a rain, if there are 10 or more classes remaining, these will be run the following day if at all possible, starting at 1:30 p.m. If not, the show will be scheduled at a later date and will be judged by the delegates. The books remain open.
13. Rain Out: The host club's President and 2 Delegates have the authority to call off a show because of rain until 7:00 am and notify the other club Delegates and the President of the Association so the judge can be notified by 8:00 am. If a show has to be called off after 7:00 am this task falls to the President of AVHSA and the Delegates. Benefit shows will be called by the AVHSA President. In the event of a rain out, AVHSA will pay for the judge to return and finish the show, after the host club has paid the initial judges fee.
14. If a judge fails to show up at a show, the show will be judged by the Delegates, or a club member selected by the Delegates. Two (2) Delegates will judge each class and their scores will be averaged out. A Delegate or a selected club member cannot judge a class in which a relative is competing.

15. Anyone moving up from Lead-In to Beginner Walk Trot or from Beginner Walk-Trot to Walk Trot cannot move back down and points accrued in the lower class will not count. All riders must ride in appropriate age division.
16. Entry fees for approved show events will be \$4.00 per entrant.
17. The contestant is responsible for errors on entry blanks and will forfeit any trophy and points awarded if later it is found he or she was ineligible for said event. A horse entered in the wrong class may be transferred to its correct class if discovered before the sign up sheet goes to the announcers stand.
18. Any drug or medication administered internally or externally, which is of such character as could affect a horse's performance, is strictly forbidden and will result in disciplinary action by the Board.
19. Running horses or riding unmanageable ones in the vicinity of the arena where spectators and/or other horses and riders are located is strictly forbidden and will result in disciplinary action by the Board. Parents will be held responsible for the conduct of their children. It is permissible to work horses in an orderly manner at a safe distance from the arena area.
20. Any contestant or any member of his immediate family who, in the opinion of the Association Board, shall be declared guilty of misconduct or unsportsmanlike behavior during any Approved Show shall immediately be suspended from any other participation in the said show. In addition, the Association can suspend such a person's right to participate in future Association Shows for such a period as deemed appropriate by the Board.
21. Every club secretary will furnish to the Association Secretary and Association Show Secretary a list of members in good standing in their club before the show season starts and update this list when new members join. For points to count toward year-end awards, the contestant's name must be on the list before the points are earned.
22. A current Coggins test (within calendar year of the show season) will be required at all Arkansas Valley Horse Show Association approved shows.
23. In the event of a serious rule infraction, one member from each club (preferably a Delegate) will accompany the President to enforce the rule. The show may be stopped, if needed, to enforce this rule.
24. Barrels will be measured each time the arena is dragged unless barrels are staked.
25. **NO RIDER RESTRAINTS ARE ALLOWED IN SPEED EVENTS** except rubber bands on feet.
26. The use of headphones or any other communication devices on riders during class will not be allowed.
27. When signing up in the sign-in book you must sign up on the next available line.
28. Contestants must state on the sign up sheet if there is to be a tack change.
29. Tack changes will be done at the back of the arena and there will be a (3) minute time limit.
30. When a Pleasure Class is called riders have three calls before the gate can be closed (the class sheet must be in the announcer's stand before the last call judged events). In Speed Events a rider has three calls before the rider is scratched and the next rider is called. Unless the rider is at the back of the arena making an attempt to enter.
31. No one is allowed to talk to the judge before or during a show. (Except: President of AVHSA, Club President from the Club having the show, and Club Members working the show.) The one thing that everyone should remember is the Judge is the official of the day and should receive the utter most respect.
32. Before any disciplinary action is taken by the Board all parties involved in the action shall have an opportunity to be heard by the Board, before the disciplinary action is voted on. This shall happen in a timely manner.
33. All Association members must represent only AVHSA at the Arkansas State Horse Show.
34. As a member of AVHSA all club members grant permission for their names, both adult and minor, to appear on the Web Site. (www.pcrer.com/AVHSA.htm)
35. No Tack Stalls are allowed at the Arkansas State Horse Show.
36. The use of mules, donkeys, burros, etc., in any event is not permitted.
37. Unless specifically addressed in the AVHSA Rule Book, the State Rule Book Rule is the guide.

RIDER AGE DIVISIONS

Pee Wee Riders will be 10 and under.
Buckaroo Riders will be 13 and under.
Junior Riders will be 18 and under.
Senior Riders will be 19 and over.

Riders must ride in only one age division when there are specific classes limited to their age division. (Example Junior Poles and Buckaroo Poles, Etc.) All riders must ride in their age division and cannot move up.

Pee Wee Riders who ride ponies can only ride in Pony Barrels, Pony Poles, and Pony Under Saddle. Pee Wee riders who ride horses over 52 must ride in Buckaroo Barrels and Poles. You can't ride in both.

Ponies can be ridden in any age division unless otherwise specified.

HORSE AGE AND EQUIPMENT CONDITION

Junior horses that are shown with a bosal or snaffle bit may be ridden with two hands on the reins.

SHOW RESULTS

The results of any approved show must include all signup sheets and entries with their club affiliation, listing the top five riders in each class and shall be sent to the Show Secretary. A check for one half (50%) of the entries shall be forwarded to the Treasurer within one week after completion of the show. Failure to submit the above within 14 days following the show date will result in disciplinary action being taken by the Board of the Association against the club failing to comply.

HIGH POINT AWARDS

The top five riders of each class of an approved show shall receive points toward the High Point Awards in the following manner:

1st.....	5 points
2nd.....	4 points
3rd.....	3 points
4th.....	2 points
5th.....	1 point

Points counted toward High Point Awards will be on the rider, not on the horse, and will only be credited to contestants who are active members of a club belonging to the Association at the time such points are earned. At the end of the last approved show of the season, or shortly thereafter, the Association will present five place High Point Awards in each of the approved events of the five riders with the greatest number of accumulated points. All ties will be broken according to the number of 1sts, 2nds, and 3rds, etc., that each tied rider has in that event. If the previous system does not break the tie, the number of shows participated in will be used. If the tie cannot be broken an additional award will be purchased.

A person must ride in an event 50 percent of the shows in order to go to the state show or to be eligible to receive their year-end high point award. If a person shows in two associations and qualifies in both, and they do not represent the AVHSA at the state show, they will not receive their year-end high point award for that year and they will not be eligible the next year.

In the event a class does not have 5 qualified riders and a rider, who has shown in 50 percent of AVHSA shows and shown in said event, may be considered to show at the State Horse Show.

JUNIOR AND SENIOR DIVISIONS

Junior Division will consist of riders 18 years and under. Senior Division will consist of riders 19 years of age and older. Age is determined by person's age of January 1. (Junior riders must ride in their division, except in events, which are open to all ages.)

In the event that a question arises on the age of a rider any time during the year, the Association can ask that birth certificates be furnished and all awards shall be held until proof of age is established.

SHOW MANAGER

The show manager shall be held responsible by the Association for enforcing all the Association's Rules and Regulations. He or she shall be the person in charge of the show. The manager shall be responsible for the maintenance of a clean and orderly show and enforce the starting time of the show as well as coordinate and expedite the movement of classes to the best of his or her ability.

Before the show date, the Show Manager should make arrangements for having programs printed and some distributed to other clubs and preparing entry sheets which should contain places for name, age (except Seniors), club affiliation and/or town if a non-club member, and making arrangements for having trophies at the show on time. The manager is responsible for obtaining the following personnel: Ringmaster, Announcer, Time Keeper, Show Secretary, at least two entry takers, at least two arena helpers, and someone to collect gate fees from non-riding spectators and check Coggins papers.

The manager shall be responsible for mailing the results of the show as covered under SHOW RESULTS to the Show Secretary of the Association.

JUDGES

Judges must be chosen from a list furnished by this Association. Neither the Judge nor member of his family may exhibit or act as agents or handlers of a horse in any class at a show where he/she is officiating. A Judge may order any person or horse from the arena for bad conduct of one or both. The Judge shall have the authority to place a horse and rider in whatever position he thinks is justified, and his decision shall be final. His authority shall be limited to decisions involving the merits of the horses and riders being judged. The Show Manager shall have the sole authority to enforce decisions involving the Rules and Regulations of the Association. The Judge may use the sifting method when class consists of 15 or more horses.

The Judge should not visit with any of the exhibitors or spectators prior to or during the show. Any conversation with the Judge should be done after the show, not prior to the show or during the show. The judge will be notified of this when contacted to judge the show.

No horse may be shown under a Judge if that Judge has been owner, trainer, or conditioner of that horse within the previous six months. If such a horse is entered in a show, its entry fee shall be refunded and it will not be exhibited. A judge may be suspended from the list of approved judges for infraction of this rule or by a majority vote of the Board of Directors of the Association.

RINGMASTER

A competent Ringmaster shall be required at all approved shows. He or she should be familiar with show procedure and etiquette. It shall be the Ringmaster's responsibility to check the qualifications as to the eligibility of each horse or pony in each event before the rider enters the ring and to excuse any ineligible riders before the judging begins. The Ringmaster shall make sure that no person rides more than one horse, or that no horse is ridden by more than one rider in any approved performance class.

By assembling the class promptly, the Ringmaster will be able to keep the judging program on schedule and eliminate delays between classes. He will notify the judge when all horses are present for the class. He will carefully refrain from advising or discussing the horses or riders with the judge.

The Ringmaster has charge of the activity in the arena. He should act as mediator between the Judge and the Announcer. He must not allow the horses to crowd up in the arena and at all times endeavor to keep the possibilities of an accident to a minimum. He has the authority to ask a rider to remove his horse for the safety of other horses, riders or spectators.

ANNOUNCER

The Announcer should give notice of approaching classes and do everything possible to expedite the show, including having entrants ready to go three deep in the timed events.

The Announcer should keep children away from the fence during the classes. He should be familiar with and announce the eligibility requirements of each class before the entrants start into the arena. He must keep his attention on the Ringmaster at all times during performance classes so as to promptly announce directions for the riders.

OTHER SHOW PERSONNEL

It is important that those responsible for taking entries (at least 2 or 3) be familiar with the eligibility requirements of the classes and be provided with proper entry forms containing places for name, age (except Seniors), and club affiliation, if any. (Entries must be paid and signed up before entry sheets are sent to the Announcer's stand at the end of the preceding class.)

It will be necessary to have at least two people in the Announcer's stand to read and record the times for the timed events, and to record the results of each event as the five place winners.

It will be necessary to have at least two Arena helpers to help the Ringmaster set up barrels, poles, and other markers for the events requiring such props and for removing them as necessary.

Unless otherwise specified, current AQHA rules will apply to those classes covered in the AQHA Rule Book. The admission fee for non-riders will be left to the discretion of the host club.

FACILITIES

Show facilities should meet minimum safety standards deemed appropriate by the Board of Directors. Any club failing to comply will be subject to disciplinary action by the Board.

Each club must see that there are adequate toilet facilities on the show ground where an approved show is held.

AMENDMENT OF BY-LAWS

These By-Laws may be amended, repealed, or altered after being proposed at one meeting of the Association Board of Directors and voted on at the next meeting.

These By-Laws, Rules, and Regulations were accepted originally on 6/21/73. They were revised on 3/18/75, 4/5/82, 3/15/83, 4/3/85, 4/7/87, 3/8/89, 3/2/92, 3/12/93, 2/7/94, 2/6/95, 3/2/98, 3/1/99, 3/6/2000, 3/3/2003, 2/2/04, 2/28/05, 2/5/07, 2/25/07, 1/14/08, 1/9/09, 1/11/10.

STATE HORSE SHOW ASSOCIATION

It should be noted that the AVHSA joined the Arkansas State Horse Show Association in January 1974. It is policy of the AVHSA Board of Directors to adopt and follow the rules and regulations of the State Association. Each year these are reviewed as they are changed or added to by the State Association. Ours will automatically change as the State Association Rules change. Each time the State Association adds or deletes new events to its approved list, the Board of AVHSA will add or delete those events deemed appropriate for our particular Association.

Each year in September, the State Association puts on a Championship Horse Show. The top five riders in each event from each of the member Associations are eligible to compete in this show. The Association must pay for five places in each event whether five people participate or not. In the event one of the top five riders is unable to go to state, substitution will be permitted moving first to 6th place and then to 7th place. Substitutions will not go beyond 7th place. Each Association must pay for assigned stalls in advance of State Show along with all entry money for participants in the Show.

Individual clubs shall be responsible for processing all forms for their entrants to the state show. Individuals shall pay their entry fees and stall fees for the state show to their respective clubs, not to AVHSA. Club Delegates or their designee shall ensure that all properly completed forms and fees in the form of a club check are forwarded to the AVHSA.

APPROVED EVENTS

LEAD IN CLASS

Age 6 and under. Any size horse. To be judged 50% on appearance, 30% on horsemanship, and 20% on the horse.

BEGINNER WALK-TROT CLASS

Age 10 and under. Any size horse. The horse will be judged at a walk, and a trot and will not be asked to back. Except for those considerations the class will be judged as a Western Pleasure Class. A child entering either of these classes cannot enter in any other judged event.

BEGINNER BARRELS and POLES

The rules for Beginner Barrels and Poles will be the same as in the Barrel Race and Pole Race with these exceptions. The age limit for Beginner Barrels and Poles is 12 and under. A horse or pony may be ridden by more than one rider. A rider must be able to sit alone on a horse or pony. A rider may not be tied or secured to a horse or pony in any manner. The rider and his/her horse/pony may be led through the pattern. A contestant riding one or both of these events Can Not Ride in another speed event except as a jumper in Open Barrel Pick-Up. In the event that a rider moves up to another speed event, the points in these classes will be null and void and the rider will not be able to ride in these classes for the remainder of the show season.

WALK-TROT

The rider will be ten years old or younger, and the horse must be over fifty-two inches in height. The horse will be judged at a walk and a trot and will not be asked to back. Except for these considerations the class will be judged as a Western Pleasure Class.

OPEN WALK-TROT

The rider will be 11 years old or older, and the horse must be over fifty-two inches in height. The horse will be judged at a walk and a trot and will not be asked to back. Except for these considerations the class will be judged as a Western Pleasure Class. All entry fees will go to the association. No year-end award for this class.

QUEEN'S CLASS

Age 21 years and under. Contestants must be female from birth, never given birth. Married, widowed or divorced contestants are not eligible. Queen's Class will be judged as follows: 50% appearance, 30% horsemanship, and 20% horse.

PONY UNDER SADDLE

Ponies 52" and under. Association president is to insure each pony is within size limit before sending entries to State. Ponies are not required to back. AQHA rules will apply. Must be shown with one hand at State.

TWO YEAR-OLD SNAFFLE BIT PLEASURE

1. Horses that have been previously shown in anything other than a snaffle bit or bosal are ineligible.
2. Horses are to be shown in standard, plain or silver headstalls (brow band, shaped ear or split ear), smooth snaffle bit with broken mouthpiece (conventional O-ring, egg butt, or D-ring with ring no larger than 4" (four) no smaller than 2" (two)); from cheek to 1" (one) in from the cheek must be a minimum three eighths diameter with a gradual decrease of the snaffle. A loose curb strap (leather or nylon only) is optional and must be attached below the reins.
3. Reins are to be attached above the curb.
4. Standard leather or woven, split reins are mandatory. Hair reins are not permitted with snaffle bits.
5. Reins must be crossed with the tails of reins on the opposite sides of the neck.
6. A braided rawhide or leather bosal may be used in lieu of a snaffle bit, no larger than 3/4" diameter at the cheek; this must be under the jaw or on the noseband in connection with the bosal. This bosal should be properly fitted relative to the horse's size and confirmation.
7. All entries must be shown with both hands on reins, maintaining light contact with the horse's mouth. The rider's hands should be carried near the pommel and not further than 4" out on either side of the saddle horn. Rider's hands should be visible to the judge(s) at all times.
8. All horses will be judged as a pleasure horse at the walk and trot only for the first 1/2 of the seasons shows. In the remaining shows, horses will be judged at the walk, trot, lope, and back as on all transitions between gaits. Horses must reverse to the inside (away from the rail). They may be required to reverse at the walk or jog, at the discretion of the judge, but shall not be asked to reverse at the lope or asked to extend to jog.
9. Horses are not to be called into the center of the arena from a jog or a lope.
10. A tight rein or excessive slack is at no time acceptable. Head carriage should be quiet and natural.
11. If a horse's mouth shows signs of broken skin, rawness or bleeding, the horse will be eliminated from competition. If a horse's nose or any area touched by the bosal shows signs of broken skin, rawness or bleeding, the horse will be eliminated from competition.
12. The following should be used as measurements for gaits: The Walk should be comfortable, flat and ground covering. The Jog should be soft, relaxed and quiet with a definite two beat. At no time should it resemble a running walk not should it be rough and stilted. The Lope should be rolling and comfortable with strong emphasis on a natural 3-beat, soft lope.
13. Horses should back on command quietly, willingly and easily in a straight line without resistance, jawing, delay and tossing of head.

BUCKAROO HORSEMANSHIP

Age 13 years and under. Horse must be over 52". AQHA rules will apply. Pattern must be posted at least thirty (30) minutes prior to class.

YOUTH HORSEMANSHIP

Age 14-18 years. Horse must be over 52". AQHA rules will apply. Pattern must be posted at least thirty (30) minutes prior to class.

WESTERN PLEASURE

Horse must be over 52". AQHA rules will apply. Only one had may be used unless other wise specified.

GIRLS: 18 years and under.

BOYS: 18 years and under.

LADIES: 19 years and older.

MEN: 19 years and older.

RANCH HORSE WESTERN PLEASURE

Horse must be over 52". This class shows the horse's ability to move at a working speed with a rider. Horses will be shown at three gaits - walk, trot and lope - in each direction of the arena. Horses will also be asked to reverse away from the rail, to stop and back. The judge may ask for an extended trot and extended lope at least one direction of the ring. A horse will be given credit for traveling with his head held in a normal position, ears alert and moving at a natural speed for the gait requested. Credit will also be given for making a smooth transition between the gaits, for keeping the correct lead, and for maintaining the gait requested until the judge requests a change. A rider must show his horse with only one hand on the reins, unless the horse is 5 years old or younger and is being shown in a snaffle bit or hackamore (bosal). Judges are encouraged to work exhibitors thoroughly, if time permits. No braided or banded manes or tail extensions. All entry fees will go to the association. No year-end award for this class.

JUNIOR HORSE PLEASURE

1. No horse older than five years of age during the current calendar year shall be allowed to participate.
2. Age of horses entered will be the responsibility of respective association presidents and will be checked only on protest. A veterinarian will be present during this class to settle any age dispute, and his decision will be accepted as final.
3. If horses are ridden with Bosal or a snaffle bit, horse may be shown with two hands.

GAITED PLEASURE

1. Horse is to be shown at a walk and favorite gait. Horses will enter the arena at a walk.
2. English or western equipment may be used.
3. This class will be judged on the performance and conformation of the horse at the discretion of the judge.
4. Open shoeing of horse is allowed.
5. The wearing of hats is optional by ladies.
6. The wearing of hats is mandatory for men.
7. One or both hands may be used on reins.
8. Gaited horses not required to back.
9. Action devices are prohibited. Exception: Protective boots, of rubber or soft leather, with no hard or sharp edges or points, not exceeding 6 oz in weight.
10. Bits with shanks in excess of 9 ½ inches in length are prohibited. Shanks are measured from the very top of the metal to the very bottom of the metal, including the rings to which the cheeks and reins are attached. See diagram, **B1**.

SLOW-GAITED PLEASURE

1. Horses should be shown with a light rein at a flat/trail walk (No Show Walk) and at a moderate rein at a favorite gait. Horses will enter the arena at a walk.
2. The horse should give the rider a pleasant ride with true road and trail qualities. He should be well mannered and responsive to the rider, displaying soundness, quality, and the ability to stand quietly.
3. The Slow Gait favorite gait will be a comfortable, smooth gait displaying no stress on horse or rider.
4. Slow gaited riders must use Western tack only and horses will be shown with split reins and with one hand only. No cavesons, nosebands, colored brow bands or ribbons are permitted. Any standard horse bit may be used, except for a gag bit with no shanks. Shanks in excess of 9 ½ inches in length are prohibited. Shanks are measured from the very top of the metal to the very bottom of the metal, including the rings to which the cheeks and reins are attached. See diagram, **B1**.

5. Shoes will be steel-foot (flat shod). Horses will be shod with one steel shoe with the frog exposed.
6. Excessive speed in this class will be penalized.
7. Gaited horses are not required to back.

Diagram: B1

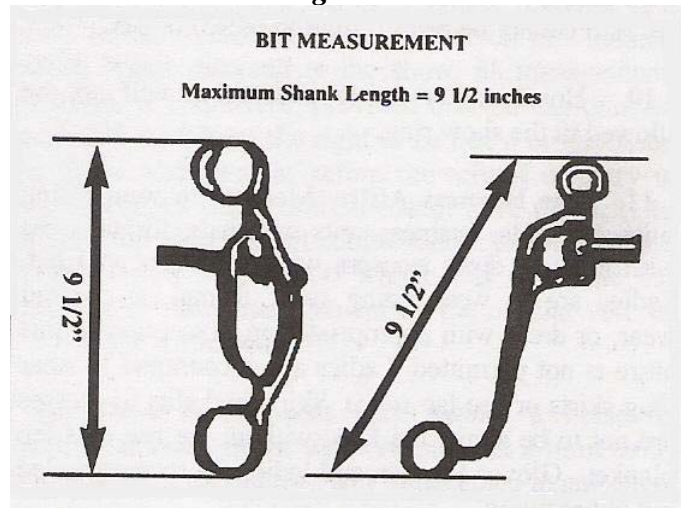

OPEN HUNTER UNDER SADDLE

1. AQHA rules will apply. Points in this class will apply to the riders' ages according to the age divisions listed in this rulebook.
2. Horses to be shown under saddle, not to jump.
3. Hunters under saddle should be suitable to purpose. They should move in a long, low frame and be able to lengthen their stride and cover ground, as in traversing hunt country following hounds. They should be obedient, alert and responsive to their riders. Quick, short strides should be penalized. Horses, which move in an artificial frame and are over flexed and behind the bit should also be penalized. Horses should be serviceably sound. Judges should emphasize free movement and manners. This class will be judged on the performance, condition and conformation of the horse; however a minimum of 20 percent of the judging shall be based on condition and conformation.
4. Horses are to be shown at a walk, trot and canter both ways of the ring. Horses should back easily and stand quietly.
5. Horses may change gaits at the flatfoot walk or the trot at the judge's discretion. Light contact with the horse's mouth is recommended.
6. In all English classes, exhibitors and judges should bear in mind that at all times; entries are being judged on ability rather than on personal attire. However, riders should wear hunt coats of traditional hunt seat style and conservative color, breeches of traditional shades of buff, gray or rust (or jodhpurs), high English boots or jodhpur shoes. Black, navy blue or brown hunting cap is mandatory. A tie or choker is required. Spurs of unrowelled type, crops or bats are optional. Hair must be neat and contained (as in a net or braid). Judges must penalize contestants who do not conform.

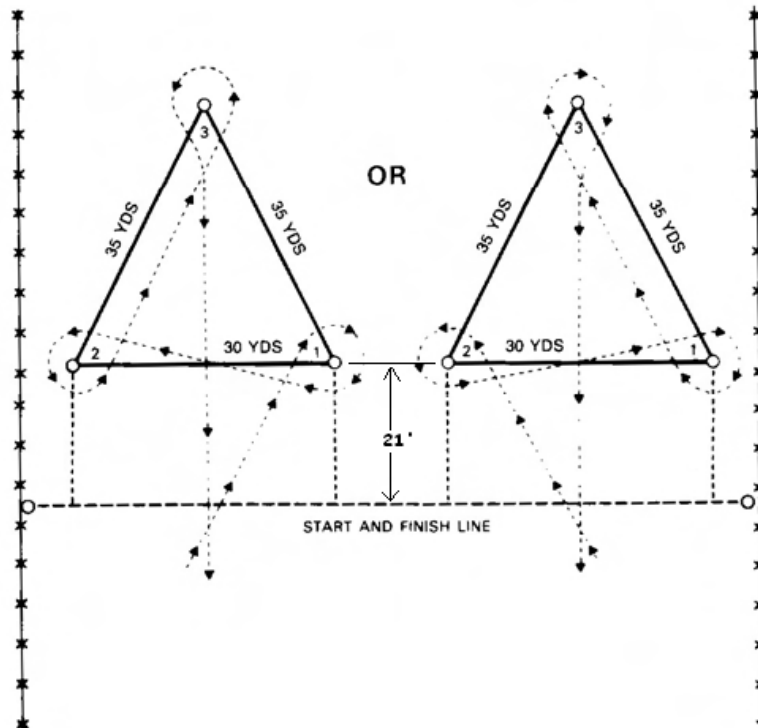

BARREL RACE

1. AQHA rules will apply except concerning wearing apparel of the riders.
2. Horses and rider may enter from either side as long as pattern is not broken and exit is made between two front barrels.
3. No barrel shall be placed closer than 15 feet from the fence.
4. Knocking over a barrel will result in disqualification.
5. Touching of the barrel by rider is permissible.
6. If a rider makes a qualified run in this event and the timer fails to work properly, the rider must make a bonafide attempt in the re-ride and will receive time even though a barrel is knocked down. NOTE: Deliberate and intentional knocking down of a barrel in order to receive a faster time will not be tolerated, and the decision of the judge will be final.
7. In the event of timer failure, a contestant may have his choice regarding time for his re-ride. He/She may run immediately, or the rider may run at the end of the event. If he/she should be the last rider in the event when the timer fails, he/she will be given five (5) minutes to rest his/her horse.
8. Pee Wee riders 10 and under who ride ponies will ride in Pony Barrels only,. Pee Wee riders 10 and under who ride horses over 52" will ride in Buckaroo Barrels only; but cannot ride in both.
 - BUCKAROO: 13 and under, any size horse
 - JUNIORS: 13 to 18, any size horse
 - SENIORS: 19 and over, any size horse

POLE BENDING PATTERN

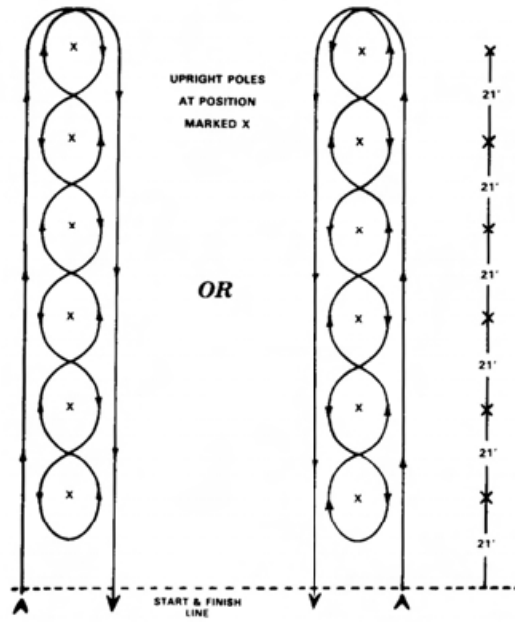

POLE BENDING

1. AQHA rules will apply except concerning wearing apparel of the riders.
2. The pole bending pattern is to be run around six (6) poles. Each pole is to be twenty-one (21) feet apart, and the first pole is to be at least twenty-one (21) feet from starting line with the last pole at least twenty (20) feet from the fence.
3. Failure to follow the pattern shall cause disqualification. If pole is knocked over, rider will be disqualified,.
4. Touching of pole by a rider is permissible and will not result in disqualification.
5. If a rider makes a qualified run in this event and the timer fails to work properly, the rider must make a bonafide attempt in the re-ride and will still receive time even though a pole is knocked over. NOTE: Deliberate and intentional knocking over a pole in order to receive a faster time will not be tolerated, and the decision of the judge will be final.
6. Re-ride time due to timer failure same as barrel race, rule number seven.
7. Pee Wee riders 10 and under who ride ponies will ride in Pony Poles only. Pee Wee riders 10 and under who ride horses over 52" will ride in Buckaroo Poles only; but cannot ride both.
 - BUCKAROO: 13 and under, any size horse
 - JUNIORS: 13 to 18 any size horse
 - SENIORS: 19 and over, any size horse.

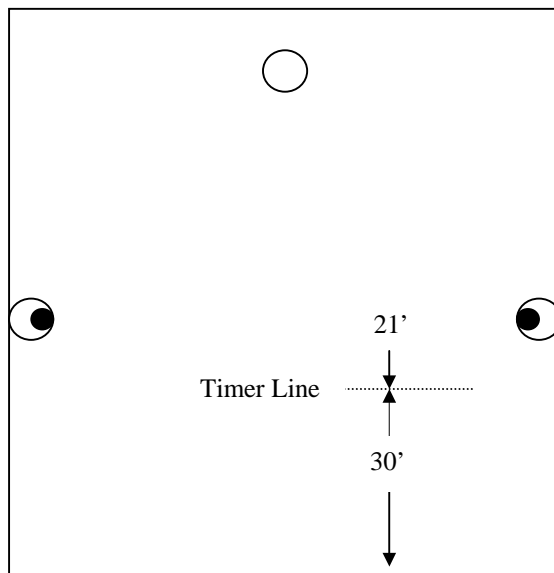

FLAG RACE

1. Flags will be 18" long with 8x9" cloth flag. Soft wood of a one (1) inch dowel rod should be used. Flag may be used as a quirt. Flagstick shall be marked three (3) inches above the bottom. Flag will be sharpened.
2. Buckets will be five (5) gallon size filled to within three (3) inches of top with masonry sand.
3. Buckets shall be placed to the inside of barrel. The flag for pick up shall be placed in the center of the bucket.
4. Upon completion of ride, barrels and buckets must be standing upright. Flag must be stuck inside bucket.
5. If any barrel or bucket in knocked over, rider will be disqualified.
6. If a rider makes a qualified run in this event and the timer fails to work properly, the rider must make a bonafide attempt in the re-ride and will still receive the time even though the rider fails to stick the flag.
NOTE: Deliberate and intentional illegal procedures executed in order to receive a faster time will not be tolerated and the decision of the judge will be final.
7. Re-ride time due to timer failure same as barrel race, rule number seven.
8. End barrel must be set in same position as for barrel race.
9. Barrels may be moved back or forward a certain distance to alleviate area around the barrels becoming dug out and dangerous.
10. Judge will place flag in pickup bucket.
Juniors- 18 and under, any size horse.
Seniors- 19 and over, any size horse

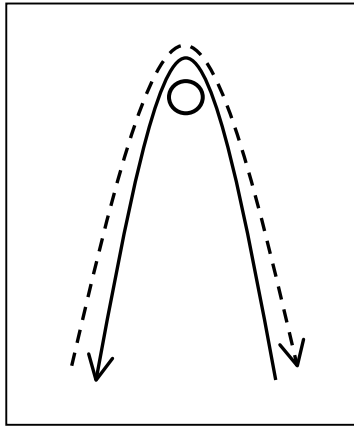

SPEED RACE

1. Rider will be disqualified if barrel is knocked over during run.
2. If a rider makes a qualified run in this event and the timer fails to work properly, the rider must run again, making a bonafide attempt in the re-ride to receive a time. NOTE: Deliberate and intentional illegal procedures executed in order to receive a faster time will not be tolerated and the decision of the judge will be final.
3. Re-ride time due to timer failure same as barrel race, rule number seven.
 - Juniors- 18 and under, any size horse.
 - Seniors - 19 and over, any size horse.

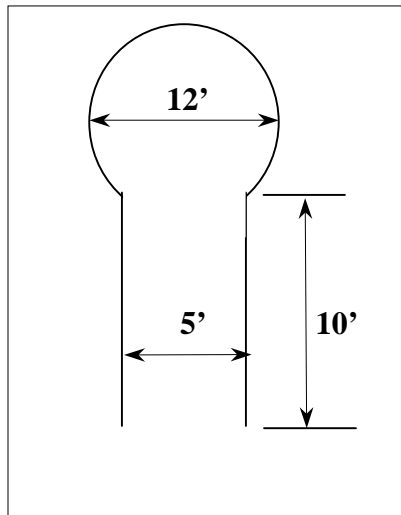

KEYHOLE RACE

1. Keyhole shall consist of a 12-foot circle with a 10 foot long by 5-foot wide throat (10'x5').
2. Horse may enter pattern with flying start. This is a timed event. Keyhole used will be outlined in white lime. Horse will follow directions as indicated in pattern diagram.
3. Horses must turn in circle not in throat or approach to circle.
4. If a horse steps in or over the line, it will be disqualified and no time will be given on the rider.
5. Judge must stand behind the keyhole or to the side at a safe distance.
6. If a rider makes a qualified run in this event and the timer fails to work properly, the rider must run again, making a bonafide attempt in the re-ride to receive a time. NOTE: Deliberate and intentional illegal procedures executed in order to receive a faster time will not be tolerated and the decision of the judge will be final.
7. Re-ride time due to timer failure same as barrel race, rule number seven.
8. Open to all ages, any size horse.

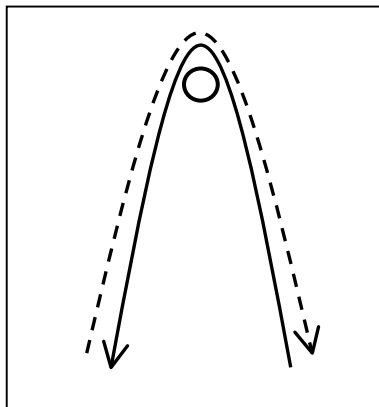

BARREL PICK UP

1. A contestant may enter only one time in this class, either as a rider or as a jumper, but not as both.
2. This race is to be run with a barrel at the opposite end of the arena. The barrel must be a least 20 feet from the fence, and the rider may ride to the right of left, circling the barrel.
3. For safety of riders in this class, the barrel is moved ten feet if necessary and is to be left to the discretion of the show manager.
4. The starting line should be at least 20 feet inside the arena.
5. The jumper must mount from the barrel and must be astride of the horse at the finish line.
6. Person being picked up must mount unassisted. Use of rider's hands at anytime during the ride is not allowed and will result in disqualification.
7. If jumper touches the ground, it will be a disqualification.
8. Judge is to be on the ground back of the barrel so as to have a better view.
9. If a rider makes a qualified run in this event and timer fails to work properly, the rider must run again, making a bonafide attempt in a re-ride to receive a time. NOTE: Deliberate and intentional illegal procedures executed in order to receive a faster time will not be tolerated and the decision of the judge will final.
10. Re-ride time due to timer failure same as barrel race, rule number seven.
11. Open to all ages, any size horse.

REINING

Junior age will be 18 and under. Senior age will be 19 and over. Current AQHA rules and patterns will apply. Reining patterns will be rotated at each show. Judge is to be notified as to which reining pattern will be used.

REINING PATTERN NUMBER 1

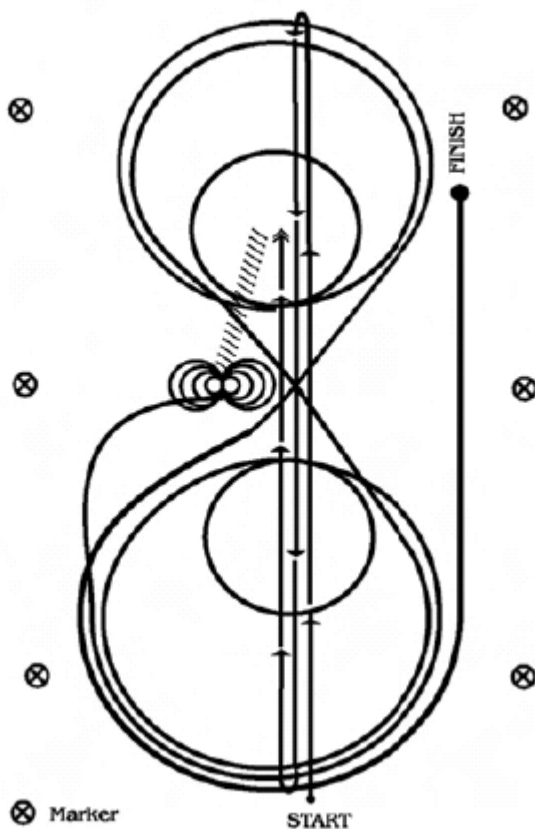

REINING PATTERN NUMBER 1

1. Run at speed to the far end of the arena past the end marker and do a left rollback - no hesitation.
2. Run to the opposite end of the arena past the end marker and do a right roll back - no hesitation.
3. Run past the center marker and do a sliding stop. Back up to center of the arena or at least ten feet. Hesitate.
4. Complete four spins to the right.
5. Complete four and one-quarter spins to the left so that horse is facing left wall or fence. Hesitate.
6. Beginning on the left lead, complete three circles to the left; the first circle large and fast; the second circle small and slow; the third circle large and fast. Change leads at the center of the arena.
7. Complete three circles to the right; the first circle large and fast; the second circle small and slow; the third circle large and fast. Change leads at the center of the arena.
8. Begin a large fast circle to the left but do not close this circle. Run straight up the right side of the arena past the center marker and do a sliding stop at least twenty feet from wall or fence. Hesitate to demonstrate the completion of the pattern.

Rider may drop bridle to the designated judge.

REINING PATTERN NUMBER 2

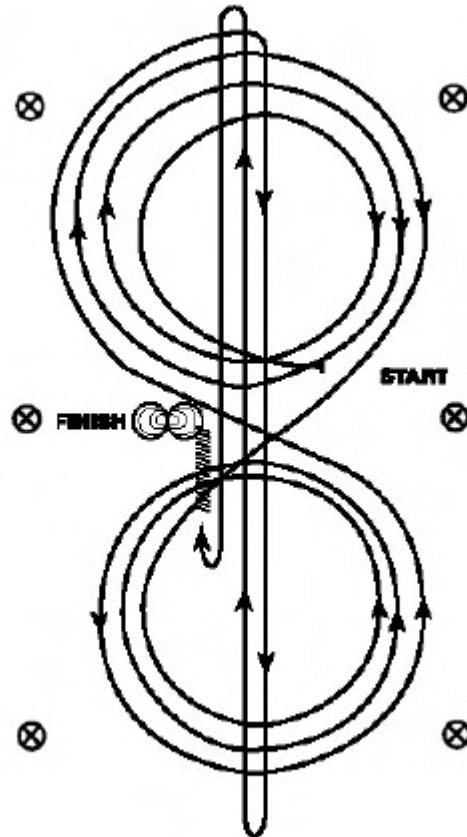

REINING PATTERN NUMBER 2

Beginning at the center of the arena facing the left wall or fence.

1. Beginning on the right lead, complete three circles to the right; the first circle small and slow; the next two circles large and fast. Change leads at the center of the arena.
2. Complete three circles to the left; the first circle small and slow; the next two circles large and fast. Change leads at the center of the arena.
3. Continue around previous circle to the right. At the top of the circle, run down the middle to the far end of the arena past the end marker and do a right rollback - no hesitation.
4. Run up the middle to the opposite end of the arena past the end marker and do a left rollback - no hesitation.
5. Run past the center marker and do a sliding stop. Back up to the center of the arena or at least ten feet. Hesitate.
6. Complete four spins to the right.
7. Complete four spins to the left. Hesitate to demonstrate the completion of the pattern.

Rider may drop bridle to the designated judge.

REINING PATTERN NUMBER 3

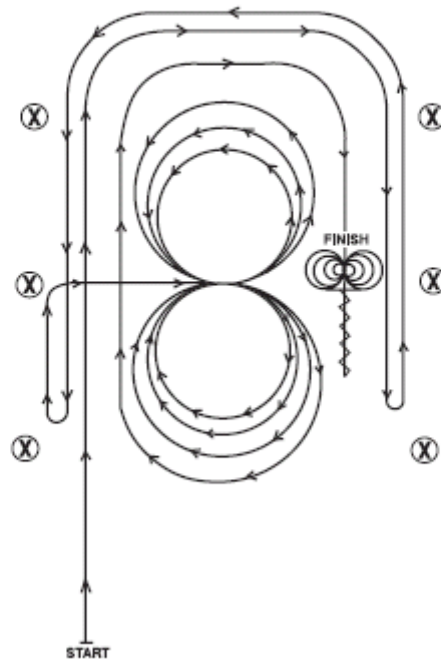

REINING PATTERN NUMBER 3

1. Beginning, and staying at least twenty feet from the walls or fence, lope straight up the left side of the arena, circle the top end of the arena, run straight down the opposite or right side of the arena past the center marker and do a left rollback - no hesitation.
2. Continue straight up the right side of the arena staying at least twenty feet from the walls or fence, circle back around the top of the arena, run straight down the left side of the arena past the center marker and do a right rollback - no hesitation.
3. Continue up the left side of the arena to the center marker. At the center marker, the horse should be on the right lead. Guide the horse to the center of the arena on the right lead and complete three circles to the right; the first two circles large and fast; the third circle small and slow. Change leads at the center of the arena.
4. Complete three circles to the left; the first two circles large and fast; the third circle small and slow. Change leads in the center of the arena.
5. Begin a large fast circle to the right but do not close this circle. Continue up the left side of the arena staying at least twenty feet from the walls or fence, circle the top of the arena, run straight down the opposite or right side of the arena past the center marker and do a sliding stop. Back up at least 10 feet. Hesitate.
6. Complete four spins to the right.
7. Complete four spins to the left. Hesitate to demonstrate completion of the pattern.
Rider may drop bridle to the designated judge.

REINING PATTERN NUMBER 4

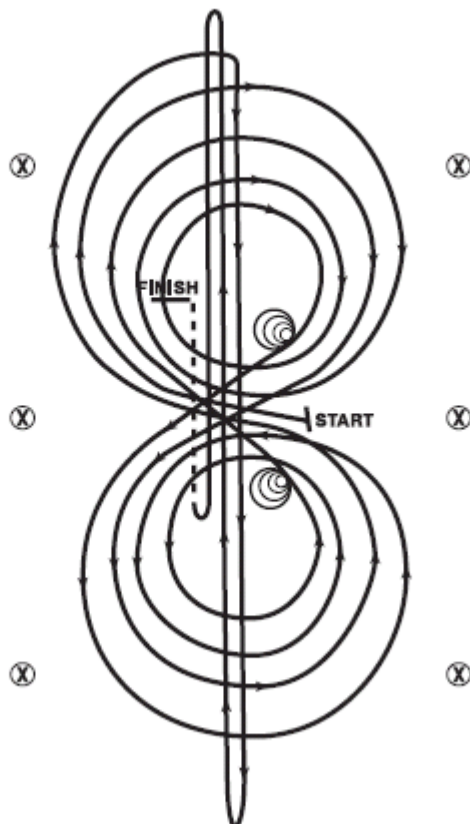

REINING PATTERN NUMBER 4

Beginning at the center of the arena facing the left wall or fence.

1. Beginning on the right lead, complete three circles to the right; the first two circles large and fast; the third circle small and slow. Stop at the center of the arena.
2. Complete four spins to the right. Hesitate.
3. Beginning on the left lead, complete three circles to the left; the first two circles large and fast; the third circle small and slow. Stop at the center of the arena.
4. Complete four spins to the left. Hesitate.
5. Beginning on the right lead, run a large fast circle to the right, change leads at the center of the arena, run a large fast circle to the left, and change leads at the center of the arena. (Figure 8)
6. Continue around previous circle to the right. At the top of the circle, run down the middle to the far end of the arena past the end marker and do a right rollback - no hesitation.,
7. Run up the middle to the opposite end of the arena past the end marker and do a left rollback - no hesitation.
8. Run past the center marker and do a sliding stop. Back up to the center of the arena or at least ten feet. Hesitate to demonstrate completion of the pattern.

Rider may drop bridle to the designated judge.

REINING PATTERN NUMBER 5

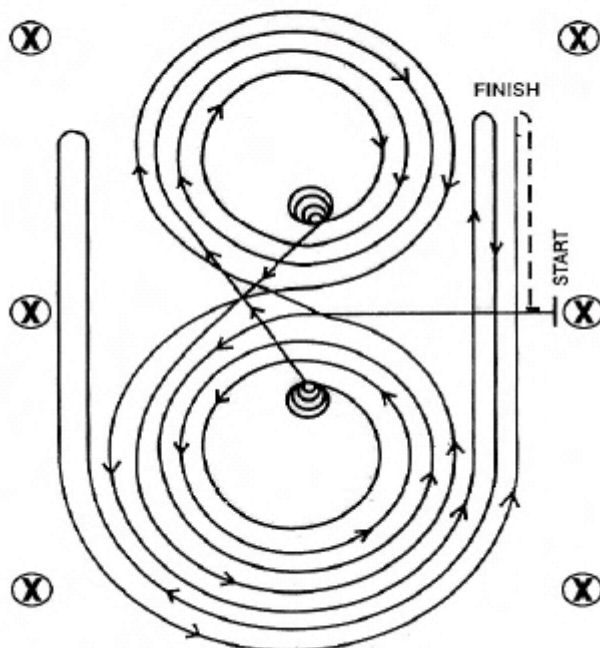

REINING PATTERN NUMBER 5

Beginning at the center of the arena facing the left wall or fence.

1. Beginning on the left lead, complete three circles to the left; the first two circles large and fast; the third circle small and slow. Stop at the center of the arena.
2. Complete four spins to the left. Hesitate.
3. Beginning on the right lead, complete three circles to the right; the first two circles large and fast; the third circle small and slow. Stop at the center of the arena.
4. Complete four spins to the right. Hesitate.
5. Beginning on the left lead, run a large fast circle to the left, change leads at the center of the arena, run a large fast circle to the right, and change leads at the center of the arena.
6. Continue around previous circle to the left but do not close this circle. Run up the right side of the arena past the center marker and do a right rollback at least twenty feet from the wall or fence - no hesitation.
7. Continue around previous circle but do not close this circle. Run up the left side of the arena past the center marker and do a left rollback at least twenty feet from the wall or fence - no hesitation.
8. Continue back around previous circle but do not close this circle. Run up the right side of the arena past the center marker and do a sliding stop at least twenty feet from the wall or fence. Back up at least ten feet. Hesitate to demonstrate completion of the pattern.

Rider may drop bridle to the designated judge.

REINING PATTERN NUMBER 6

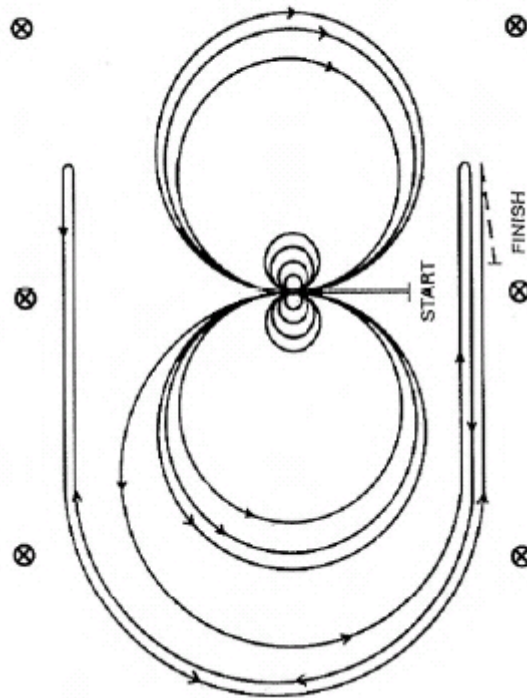

REINING PATTERN NUMBER 6

Beginning at the center of the arena facing the left wall or fence.

1. Complete four spins to the right.
2. Complete four spins to the left. Hesitate.
3. Beginning on the left lead, complete three circles to the left; the first two circles large and fast; the third circle small and slow. Change leads at the center of the arena.
4. Complete three circles to the right, the first two large and fast; the third circle small and slow. Change leads at the center of the arena.
5. Begin a large fast circle to the left but do not close this circle. Run up the right side of the arena past the center marker and do a right rollback at least twenty feet from the wall or fence - no hesitation.
6. Continue back around previous circle but do not close this circle. Run up the left side of the arena past the center marker and do a left rollback at least twenty feet from the wall or fence - no hesitation.
7. Continue back around previous circle but do not close this circle. Run up the right side of the arena past the center marker and do a sliding stop at least 20 feet from the wall or fence. Back up at least ten feet. Hesitate to demonstrate the completion of the pattern.

Rider may drop bridle to the designated judge.

REINING PATTERN NUMBER 8

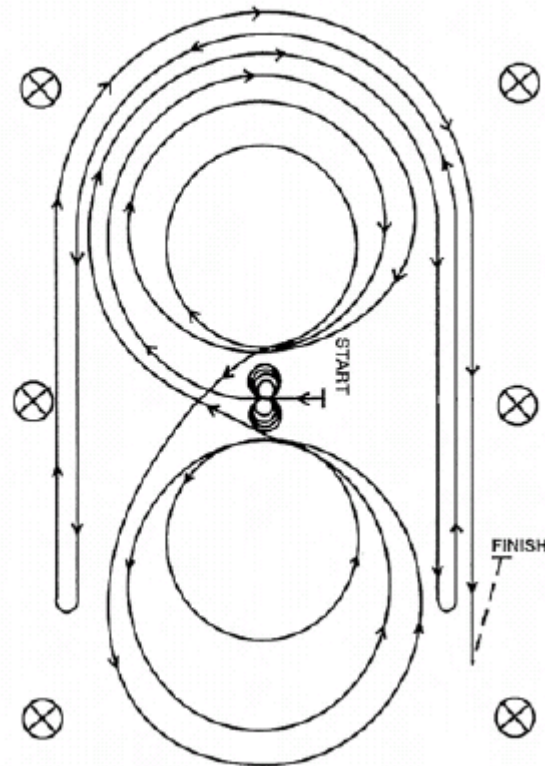

REINING PATTERN NUMBER 8

Beginning at the center of the arena facing the left wall or fence.

1. Complete four spins to the left.
2. Complete four spins to the right. Hesitate.
3. Beginning on the right lead, complete three circles to the right; the first circle large and fast; the second circle small and slow; the third circle large and fast. Change leads at the center of the arena.
4. Complete three circles to the left; the first circle large and fast; the second circle small and slow; the third circle large and fast. Change leads at the center of the arena.
5. Begin a large fast circle to the right but do not close this circle. Run straight down the right side of the arena past the center marker and do a left rollback at least twenty feet from the wall or fence - no hesitation.
6. Continue back around the previous circle but do not close this circle. Run down the left side of the arena past the center marker and do a right rollback at least twenty feet from the wall or fence - no hesitation.
7. Continue back around the previous circle but do not close this circle. Run down the right side of the arena past the center marker and do a sliding stop at least twenty feet from the wall or fence. Back up at least ten feet. Hesitate to demonstrate completion of the pattern.

Rider may drop bridle to the designated judge.

REINING PATTERN NUMBER 9

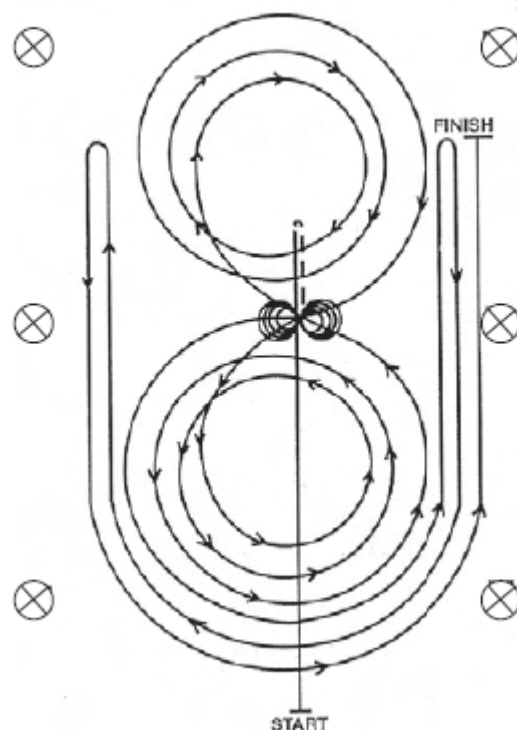

REINING PATTERN NUMBER 9

1. Run past the center marker and do a sliding stop. Back up to the center of the arena or at least ten feet. Hesitate.
2. Complete four spins to the right.
3. Complete four and one-quarter spins to the left so that horse is facing the left wall or fence. Hesitate.
4. Beginning on the left lead, complete three circles to the left; the first circle small and slow, the next two circles large and fast. Change leads at the center of the arena.
5. Complete three circles to the right, the first circle small and slow, the next two circles large and fast. Change leads at the center of the arena.
6. Begin a large fast circle to the left but do not close this circle. Run up the right side of the arena past the center marker and do a right rollback at least twenty feet from the wall or fence - no hesitation.
7. Continue back around the previous circle but do not close this circle. Run up the left side of the arena past the center marker and do a left rollback at least twenty feet from the wall or fence - no hesitation.
8. Continue back around previous circle but do not close this circle. Run up right side of the arena past the center marker and do a sliding stop at least twenty feet from the wall or fence. Hesitate to demonstrate completion of the pattern.

Rider may drop bridle to the designated judge.

REINING PATTERN NUMBER 10

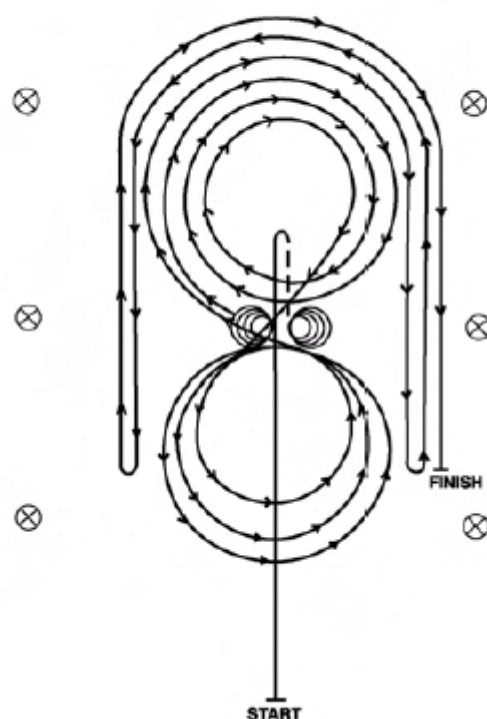

REINING PATTERN 10

1. Run past the center marker and do a sliding stop. Back up to the center of the arena or at least ten feet. Hesitate.
2. Complete four spins to the right.
3. Complete four and one-quarter spins to the left so that the horse is facing the left wall or fence. Hesitate.
4. Beginning on the right lead, complete three circles to the right; the first two circles large and fast, the third circle small and slow. Change leads at the center of the arena.
5. Complete three circles to the left; the first circle small and slow, the next two circles large and fast. Change leads at the center of the arena.
6. Begin a large fast circle to the right but do not close this circle. Run down the right side of the arena past the marker and do a left roll back at least twenty feet from the wall or fence - no hesitation.
7. Continue back around the previous circle but do not close this circle. Run down the left side of the arena past the center and do a right roll back at least twenty feet from the wall or fence - no hesitation.
8. Continue back around previous circle but do not close this circle. Run down the right side of the arena past the center marker and do a sliding stop at least twenty feet from the wall or fence. Hesitate to demonstrate completion of pattern.

Rider may drop bridle to the designated judge.